

**MARKET TIMING**

# Log Spirals In The Stock Market

*The basic mathematical characteristic of the log spiral is that even while increasing or decreasing in size, the log spiral remains constant. This is also true for rectangular spirals, the parameters of which are determined by their related log spirals. Many major market moves share the properties and predetermined progression of these spirals, indicating the close correlation between multiple manifestations of the ordered form of nature and the architecture of markets themselves.*

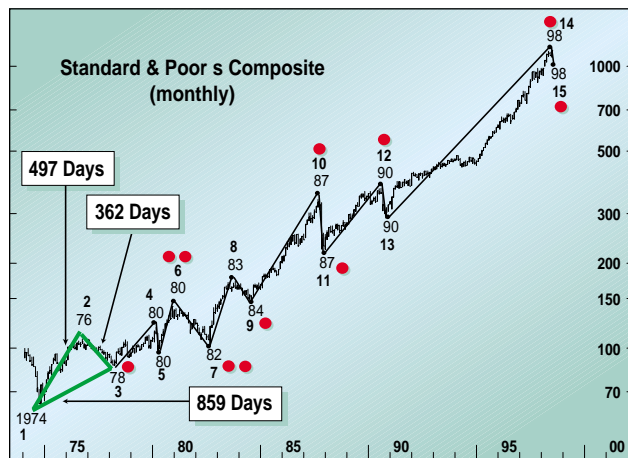
by William T. Erman



Three important turning points between 1974 and 1978 have influenced the growth pattern of many subsequent major and minor market moves, up to and including the July 20, 1998, peak and the September and October 1998 lows for the Dow Jones Industrial Average (DJIA) and the Standard & Poor's 500, respectively. Here's how the triangle in Figure 1, which connects the 1974 low for the S&P 500 index with the 1976 peak and 1978 low, have influenced these subsequent market moves. The triangle seen here connects points 1, 2, and 3 from Figure 2. The points in Figure 1 and 2 are those moves analyzed in this article.

## THE CASE FOR ORDER

Before proceeding to the examples, let us review two schools



**FIGURE 1: SPIRAL GROWTH PATTERNS.** Points 1, 2, and 3 are connected, forming a triangle. These points influence the growth pattern of many subsequent major and minor moves in the market. The dots represent those moves examined in this article.

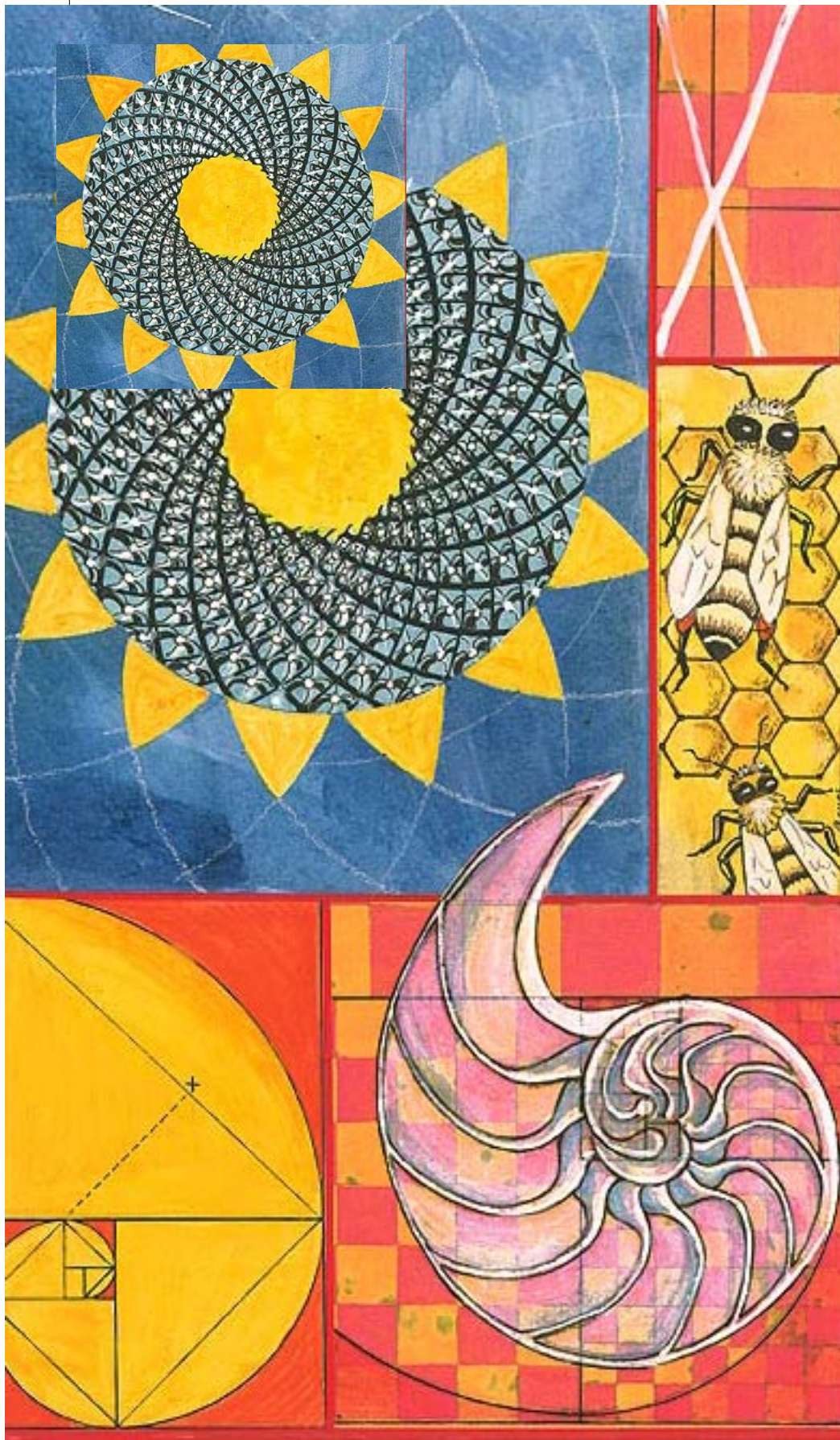
of thought regarding order in the markets and some properties of log spirals. Technical analysis has made amazing progress since the advent of computers, but this progress has not quieted the debate between random walk proponents and advocates of mathematically ordered markets. Random walk supporters cite the millions of subjective, individual decisions and unpredictable fundamental events as sufficient reasons for the impossibility of ordered markets. The opposing philosophical argument in support of orderly markets is based on the following:

- Market moves are the result of the psychological factors translated into market-moving decisions by the aggregate of participants. The participants are human beings.
- Humans are indisputably a part of nature.
- As a product of humankind, markets are as inherently natural as thousands of geometrically perfect honeycombed beehives produced by billions of bees.
- From the atom, to living organisms at every level, to the farthest extent of the cosmos, nature exhibits the ability to create order out of an infinite number of seemingly chaotic inputs. Order endures, unscathed by a perpetual barrage of potentially disruptive influences.

### DATE LIST

1	S&P, October 4, 1974	• 6A	DJIA, April 27, 1981	11	October 20, 1987
• 1A	DJIA, December 22, 1974	7	S&P, August 9, 1982	12	July 16, 1990
2	September 22, 1976	• 7A	DJIA, August 12, 1982	13	October 10, 1990
3	March 1, 1978	8	October 11, 1983	14	July 20, 1998
4	February 13, 1980	• 8A	November 30, 1983	15	DJIA, September 1, 1998
5	March 27, 1980	9	July 25, 1984	• 15A	S&P, October 8, 1998
6	S&P, November 26, 1980	10	August 25, 1987		

**FIGURE 2:** This list represents the dates for corresponding numbered chart points in Figure 1. The dotted points denote when the DJIA and S&P reverse on different days; both dates are used in this situation. This is referred to a *compound pivot*.



Our work provides the mathematical basis and evidence (see sidebar, “Ermanometry Principles”) that the markets are merely a microcosm of the larger natural universe in which they exist. As children of nature, markets digest and convert their myriad inputs into orderly progressive patterns of growth, both in time and price.

One of the best-known examples of orderly progression in nature is the *nautilus* mollusk; a half-section view of its shell can be seen in Figure 3. As its growth forces the shell to increase in size, the essential shape of the shell never changes. The radius increases proportionately as the shell grows longer. Successive increments of growth are united by a constant, common ratio of expansion.

Figure 4 approximates the spiral growth curve of the nautilus. Two perpendicular lines, similar to polar axes, have been drawn through the center of the spiral at point X. As the spiral curves around point X, it crosses the axes at a series of points labeled A through J. These points have been connected with a series of straight lines. Each line is perpendicular to the preceding and successive lines in the series. Adjoining pairs of these lines are the legs of successively larger right triangles, with segments of the axes forming the hypotenuse of each triangle. In Figure 4, the triangle EFG has legs EF and FG, and axis segment EG is the hypotenuse.

Also in Figure 4, the line series A-J is a *rectangular spiral*. Extension of any line in the series A-J, past the point at which it meets an adjacent line in the series to the point at which it intersects another line in the series, creates a rectangle. For example, if line GF is extended to intersect line IJ at point Z,

BARBARA BRUCH

then points Z, I, H, and G are the four corners of a rectangle.

The axes segments have the same constant growth ratio as the spirals. Therefore, the diagram could be turned inside out using the axes segments as the rectangular spiral. The values for the previous rectangular spiral segments would then become axes segments. The shape of the log spiral would remain constant.

### MARKET TIME IS SPHERICAL

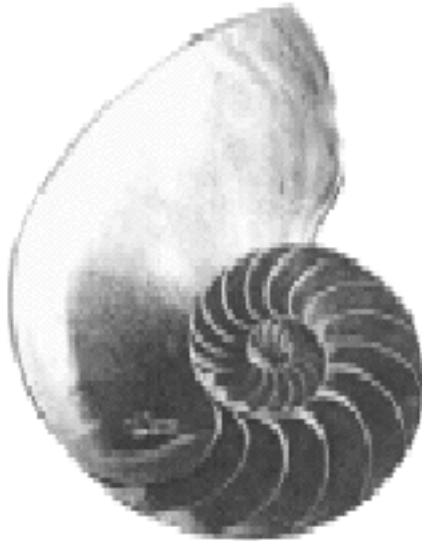
All markets exhibit orderly growth patterns in both time and price. Ermanometry considers time to be the dominant influence on market movements, and the examples herein will concentrate on time. There are always multiple growth patterns influencing the market at any given time. In classical cyclical analysis, a 40-week cycle might be moving up while a 40-month cycle is moving down, and the analyst seeks to find the point when the majority of long- and short-term cycles are in sync, due to tops and bottoms together within a relatively short time span. The analysis of growth patterns is similar in that the analyst looks for that place in time where several growth patterns intersect.

Classical analysis views market time as always moving forward. A new cycle of any given length is expected to begin where the previous cycle ends. Growth pattern analysis perceives market time as spherical and multidimensional. Growth segments are contiguous, but the essence of their continuity is skewed when portrayed on the plane.

Paradoxically, two contiguous segments may be separated by long periods on the plane. This phenomenon is similar to the difference in perspective that would arise if a flat map of the Earth were wrapped around a globe. It would be obvious that it would not fit the space allotted, and the result would bear little resemblance to the true thing. A spherical perspective requires that time be seen as revolving, and analysis performed clockwise and counterclockwise, so that growth pattern segments not evident on the plane may be considered.

As few as three segments may be used for proper analysis. This would be equal to 270 degrees, or three-quarters of a complete revolution of the log spiral. Values for market moves may appear and reappear in different geometrical shapes. A straight line may appear as a circle or triangle, or as a series of noncontiguous straight lines.

The book *Ermanometry* provides many different methods for understanding and decoding the future path of spherical market movements.



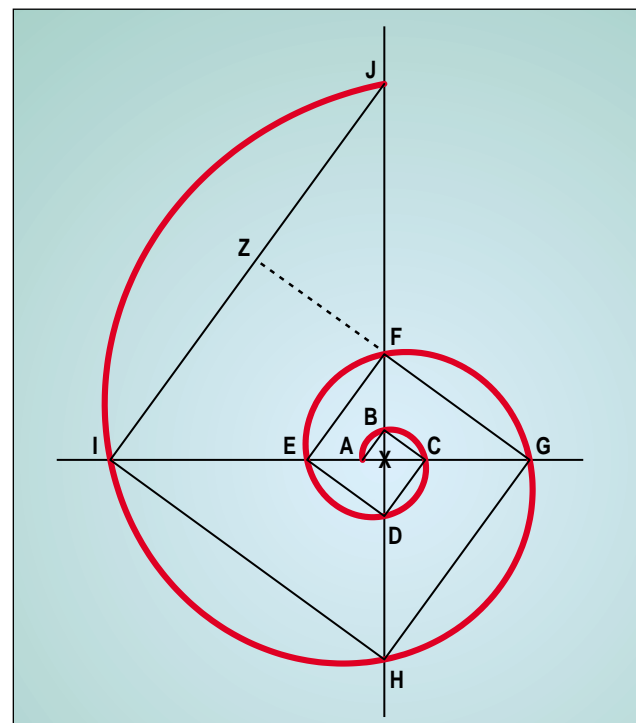
**FIGURE 3: NAUTILUS SHELL.** Here is a half-section view of a nautilus shell. Successive increments of growth are united by a constant common ratio of expansion.

### IDENTIFYING THE SPIRALS

The starting point for uncovering spiral growth patterns is at major market pivots. *Major*, of course, is a relative term, and its quantification depends upon the time frame being analyzed. Analysis of short-term patterns — 15-minute bars — might require only that the search start at the beginning of the current minor trend. For macroanalysis of long-term trends, it is necessary to begin as far back as available data permits. The examples herein will cover the current long-term patterns, and I will use 1974 as a starting point.

After the Great Depression low in 1932, both the DJIA and S&P reached their then-historical nominal price peaks in 1973. Nominal highs, as opposed to constant dollar/inflation-adjusted historic highs, were reached by the DJIA in 1966 and by the S&P in 1968. The lows in 1974 represented the lowest nominal prices reached after the 1973 peak, and many analysts consider 1974 as the true beginning of the macro bull market today.

The S&P and DJIA reached their extreme intraday lows 45 trading days apart, and therefore, the 1974 bottom is what we



**FIGURE 4: LOG SPIRAL.** A log spiral of the nautilus shell, together with a rectangular spiral (bounded by the log spiral), are displayed.

**ERMANOMETRY PRINCIPLES**

The day count and determination of turning points for the market moves illustrated in this article are based on certain principles of Ermanometry. Following is a brief explanation of the pertinent principles:

- *Pivot*: The day when a specific market move, either up or down, reaches its extreme intraday high or low price. Closing prices are not considered.
- *Measuring time*: Time is measured in increments as small as 15 minutes. The largest increment is a single trading day. Time is never measured in weeks or months. Ermanometry does not count days when the markets do not trade.
- *Compound pivot*: The S&P and DJIA are considered one market and are always analyzed in concert. A compound pivot occurs when the two indices record their extreme prices on different days. Currently, both made their high extremes on July 20, but their lows were made 26 trading days apart: September 1, and

October 8. Each of these low days represents the lowest intraday price subsequent to the July 20th top. Therefore, they are identified as two components of a compound pivot. The components are interchangeable and may be mixed and matched — time may be measured from a previous pivot to all components of a compound pivot. It is quite common to measure from a DJIA pivot to an S&P pivot, and vice versa. The properties of the DJIA and S&P pivots are shared by a third pivot, termed the balance point. A balance point is that day precisely in between the two index pivots. Therefore, the balance point for the September 1st and October 8th index pivots would be 13 days forward from the DJIA low and 13 days back from the S&P low.

- *Ermanometry allows for a maximum error factor of two days*. This margin holds regardless of the length of moves being analyzed, including moves of 20,000 days or more.

—W.T.E.

refer to as a compound pivot: S&P, October 4, 1974; DJIA, December 9, 1974. Both indices made important lows on both days, but the DJIA made a lower low on December 9 and the S&P held above its October 4th low. Since the S&P pivot came first, it is the logical starting point for identifying a macro log spiral.

The first move of sufficient importance considered in identifying a macro log spiral is the advance from the S&P 1974 low to the 1976 top. On Figure 1, the heavy line connecting points 1 and 2 shows this 497-day move. The second move is the decline from 1976 to 1978, points 2 and 3, 362 days. The third move is from the 1974 low to the 1978 low, points 1 and 3, 859 days. Ermanometry considers the time distance between any two important pivots as a separate and distinct move, even if it encompasses other important moves. Though the 859 days from low to low (points 1 and 3) have already been considered a 497-day advance and a 362-day decline, the 859 days are treated as a third move.

Only two moves, which will be referred to as *seed segments* when referring to log and rectangular spirals, can be used to initially identify growth patterns because a constant ratio of growth must be established. The 497- and 362-day segments will be used first:

**Step 1:** Calculate the ratio between 497 and 362:

$$497/362 = 1.37293$$

The inverse of the ratio must also be calculated so that the spiral may wind counterclockwise as well as clockwise:

$$1/1.37293 = 0.72836$$

A minimum of three segments, 270 degrees/three quadrants, should be used when rotating counterclockwise.

**Step 2:** Place the seed segment values, 362 and 497, on segments

DE and EF of the rectangular spiral. Using DE and EF allows for three segments counterclockwise. (See Figure 5.)

**Step 3:** The values for the remaining segments of the rectangular spiral may be calculated using the constant growth/decay ratios derived in step 1.

$$(497)(1.37293) = 682.35$$

$$(682)(1.37293) = 936.81, \text{ etc.}$$

The following table shows the values for the rectangular spiral segments:

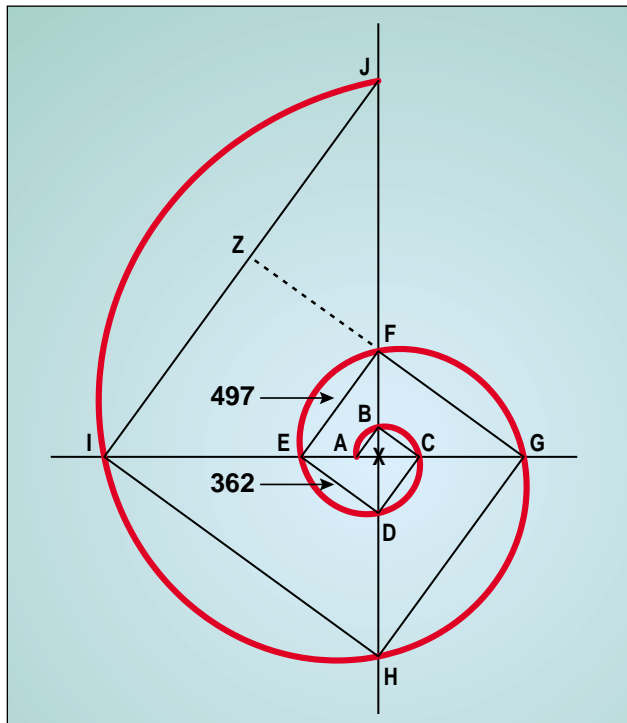
**Segments**

AB = 139.88
BC = 192.05
CD = 263.67
DE = 362.00 (seed segment)
EF = 497.00 (seed segment)
FG = 682.35
GH = 936.81
HI = 1,286.17
IJ = 1,765.83

**EXAMPLES**

Numerous techniques exist for relating the spiral segments to important tops and bottoms in the stock market. Refer to Figure 2 for the numbered points on the charts. The dates designated with an "A" are compound dates; for example, points 6 and 6A represent the peaks for the S&P in 1980 and the DJIA in 1981, 103 days apart. These points are the extreme highs for the respective indices after the 1980 low, and together, they make up a compound pivot.

Figure 6 begins the illustrations of how the various segments of the spiral constitute future market moves. The sum of the two seed segments, DE and EF, added to the segment 90-degree counterclockwise, CD, totals 1,122.67 days. This



**FIGURE 5: SEED SEGMENTS.** The seed segment values are placed on the segments DE and EF of the rectangular spiral.

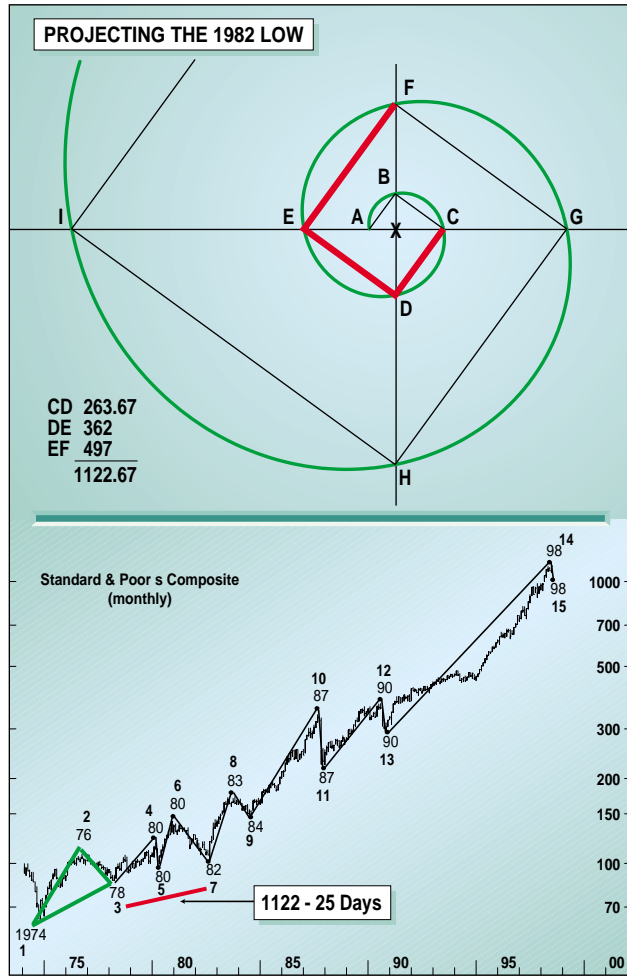
is the number of days from point 3, the 1978 low, to the 1982 low. Three perpendicular lines, or 270 degrees, become a single straight line that is the four-year move.

Moving ahead, Figure 7 shows how the two seed segments clockwise, 180 degrees, add up to the entire 10-year move, 1974-84. While Figure 6 showed how three perpendicular lines straightened themselves out to become an important move, Figure 7 shows how four perpendicular lines, one complete revolution of the spiral, equate an important 10-year move.

Another technique to project turning points is to use the Pythagorean theorem. Figure 8 shows an example of using the axis segments for projections. The Pythagorean theorem can be used to calculate the value of each axis segment. Because of the reversing inside-out character of the structure and identical growth ratio, axis segments are additional tools for projections. The two axis segments summed in Figure 8 represent the advance from the 1978 low to the S&P peak in 1980, point 6.

The next technique is to use a single axis segment for projections. Examining Figure 9 reveals that the 1,159-day time distance value for FH exactly equals the days from the 1976 peak (both indices) to point 6A, the 1981 DJIA peak. Points designated with an "A" do not appear separately on the chart, and therefore, the 1,159-day line connects points 2 and 6 instead of points 2 and 6A.

Figure 10 is the sum of the six axis segments, and the results constitute the entire advance from 1974 to 1987. The error in this example is 1.32 days, within the allowed toler-



**FIGURE 6: PROJECTING THE 1982 LOW.** Points 1, 2, and 3 are called seed points. All seed points are valid points from which to project forward, with values derived from the spirals. When a projected point does in fact become an important pivot, that new pivot is considered part of the spiral family and becomes a valid point from which to project forward.

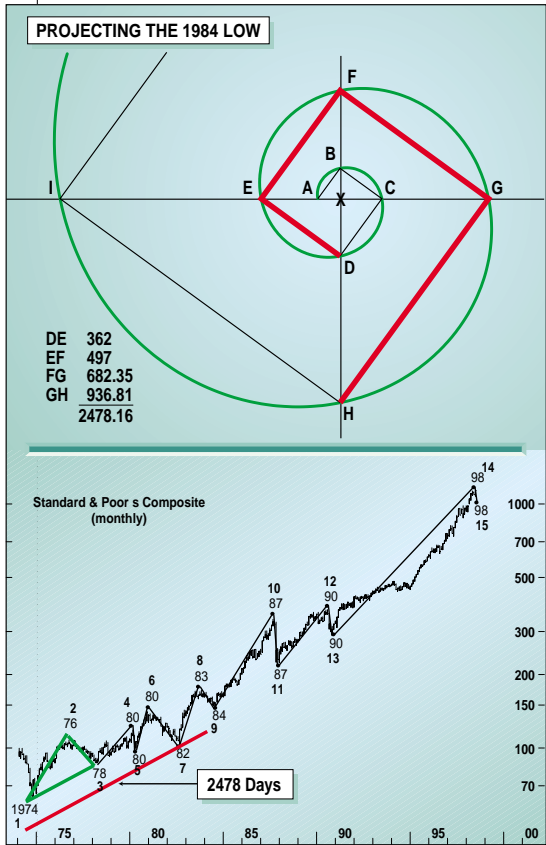
ance of two days.

What about the crash low in 1987? Figure 11 shows how the four spiral segments connect the 1982 low with the crash low of 1987. Note that segments CD, DE, EF connected the 1978 low to the 1982 low. (Refer to Figure 6.) The addition of one more segment counterclockwise, BC, by 90 degrees, and the total added to the 1982 low completes the entire move from 1974 to 1987, low to low.

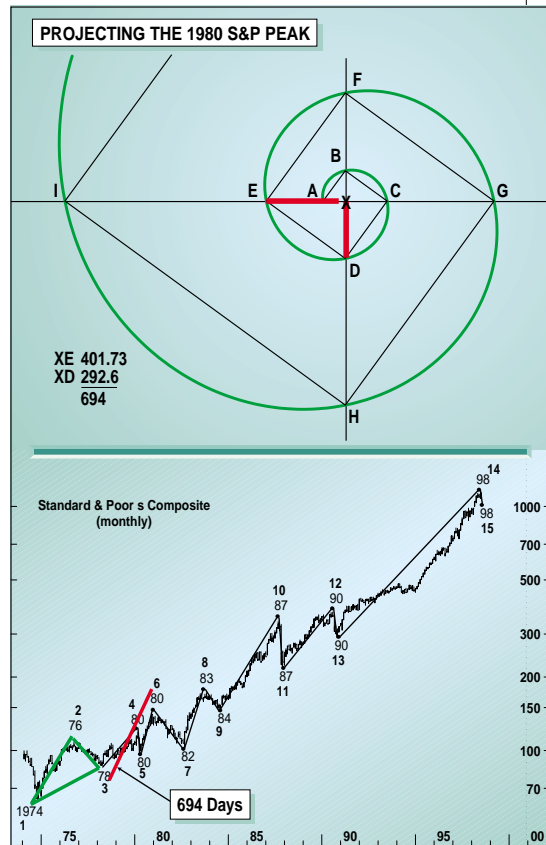
If we extend our range and use the larger spiral segments, we can see that in Figure 12, we can project more distant pivots. The projection missed the actual pivot day by 1.8 days. However, as in all growth pattern analysis, multiple spirals, from many different time frames, were used to confirm this projection.

The peak in the market that occurred in the summer of 1998 is examined in Figure 13. The first three spiral segments totaled the move illustrated in Figure 6. The next two segments, FG and GH, total 1,619 days, the move from 1978 to 1984. In Figure 6, this move is shown emanating from the

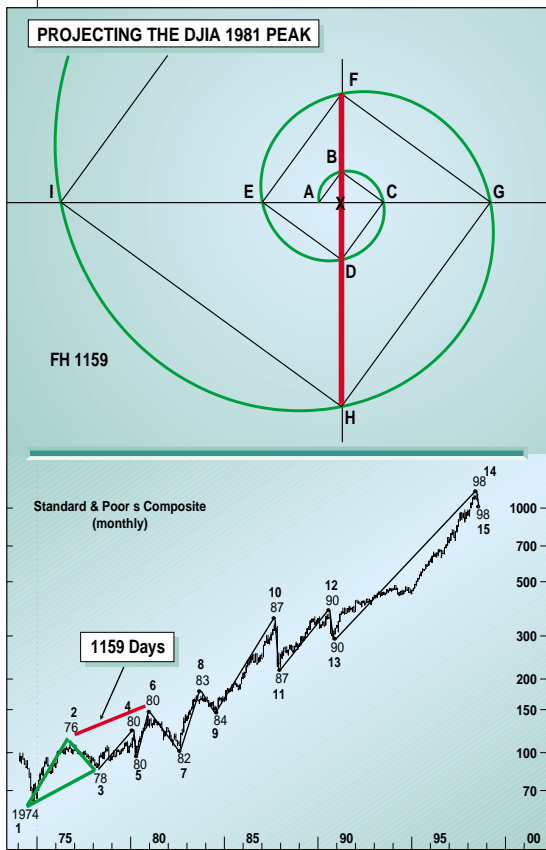
TOPLINE INVESTMENT GRAPHICS



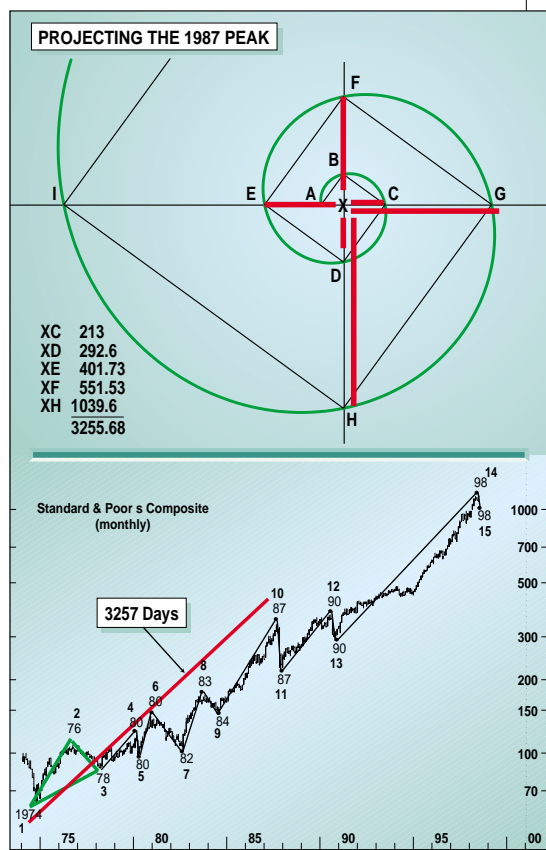
**FIGURE 7: 10-YEAR 1974-84 MARKET ADVANCE, TWO SEED SEGMENTS AND 180 DEGREES CLOCKWISE.** In Figure 6, three perpendicular lines straightened themselves out to become an important move. Here, four perpendicular lines—one complete revolution of the spiral—equate an important 10-year move.



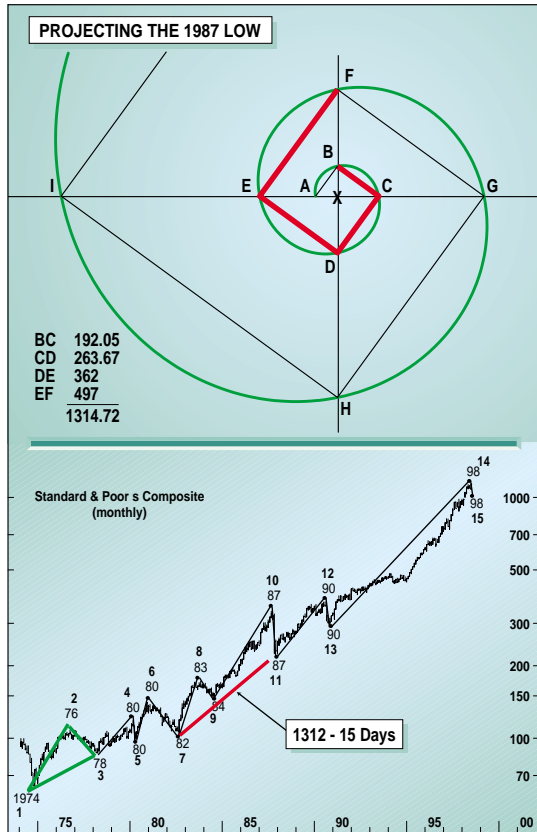
**FIGURE 8: AXIS SEGMENTS FOR PROJECTIONS.** The Pythagorean theorem can be used to calculate the value of each axis segment very easily. Because of the reversing inside-out character of the structure and identical growth ratio, axis segments are additional tools for projections. The two axis segments summed in Figure 8 represent the advance from the 1978 low to the S&P peak in 1980, point 6.

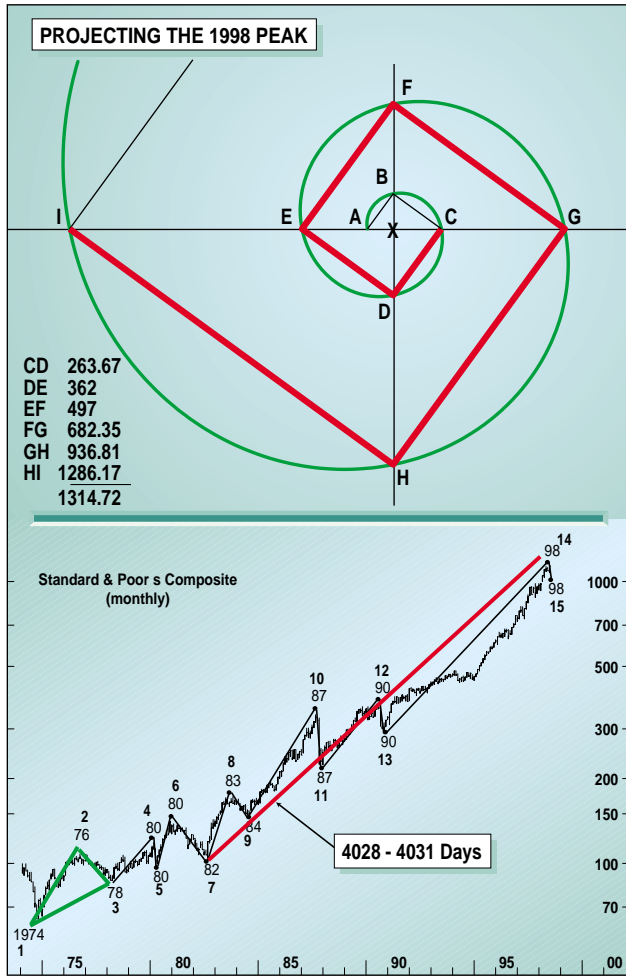


**FIGURE 9: SINGLE-AXIS SEGMENT.** The 1,159-day time distance value for FH exactly equals the days from the 1976 peak (both indices) to point 6A, the 1981 DJIA peak. Points designated with an A do not appear separately on the chart, and therefore, the 1,159-day line connects points 2 and 6, instead of 2 and 6A.



**FIGURE 10: SIX AXIS SEGMENTS.** The six axis segments constitute the entire advance from 1974 to 1987. The error in this example is 1.32 days, within the allowed tolerance of two days.





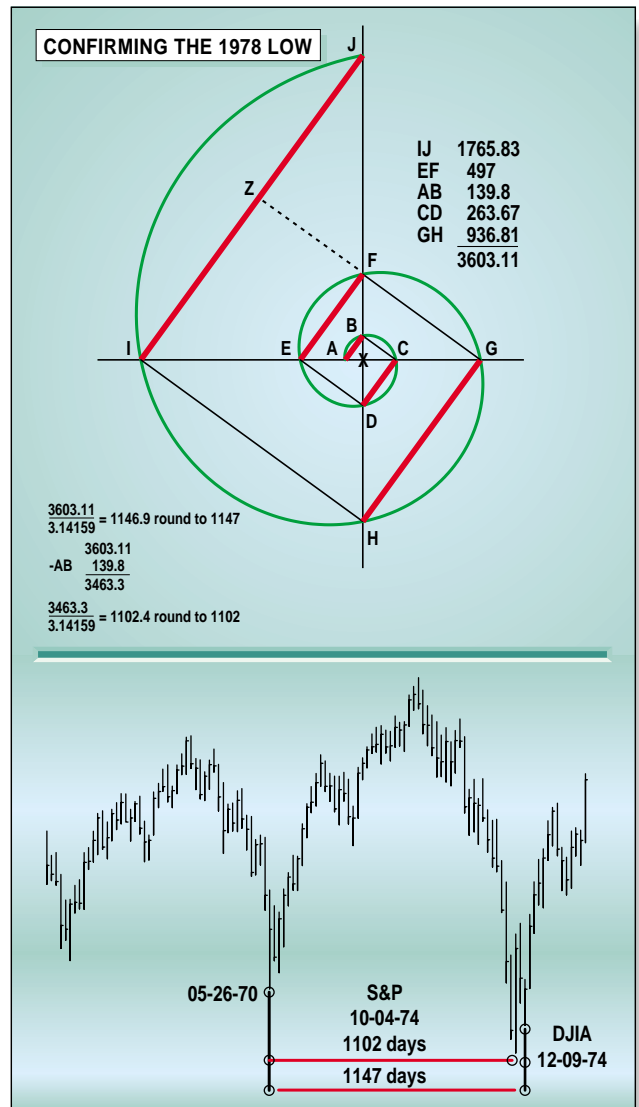
**FIGURE 13: SUMMER 1998 PEAK.** The first three spiral segments totaled the move illustrated in Figure 6. The next two segments, FG and GH, totaled 1,619 days, the move from 1978 to 1984. In Figure 6, this move is shown emanating from the 1974 low because the seed segments were included. The addition of the successive spiral segment, HI, brings the totals to 4,028, which is the exact number of days from August 12, 1982, to July 20, 1998.

The 1,102 represents the time distance from the 1970 low to the 1974 S&P low.

The diameters representing the moves from the 1970 low to both the 1974 S&P and DJIA pivots, at the 1974 low, resulted in circles seen in the spiral segments. Market time “reincarnates” itself in related geometrical shapes. The analyst would consider the appearance of permutations of two previous market moves in spirals anchored by the 1978 low as confirmation of an important low.

**A NEW CONFIRMING SPIRAL**

The two seed segments used thus far are 497 and 362. These segments are the advance from 1974 to 1976, and the decline from 1976 to 1978. A second set of seed segments is now used to calculate a new spiral. The first seed segment is the advance of 497 days, used previously. The second seed segment is 859, the sum of the 497-day advance and the 362-day decline, and



**FIGURE 14: DIFFERENT GEOMETRIC SHAPES.** The time distance from the 1970 low to the S&P low in 1974 is 1,102 days, and 1,147 days to the DJIA low in 1974.

therefore, the time distance from the 1974 low to the 1978 low.

**Step 1:** Calculate the ratio between 859 and 497:

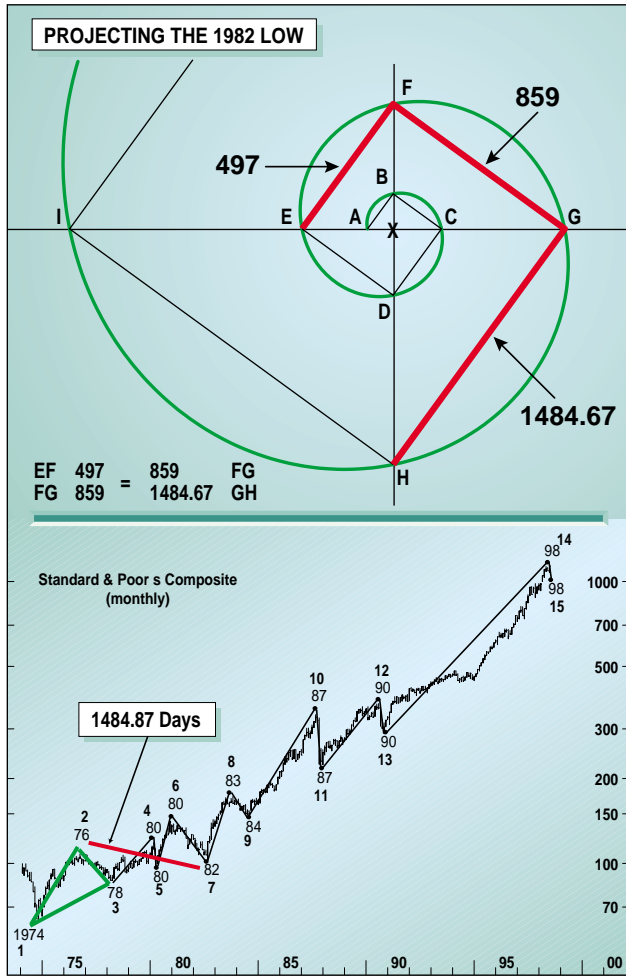
$$859/497 = 1.72837$$

The inverse:  $1/1.72837 = 0.57858$

**Step 2:** Place the seed segment values, 497 and 859, on segments EF and FG of the rectangular spiral.

**Step 3:** The value for the remaining segments of the rectangular spiral may be calculated using the constant growth/decay ratios derived in step 1.

*Seed segment*  
AB = 55.69



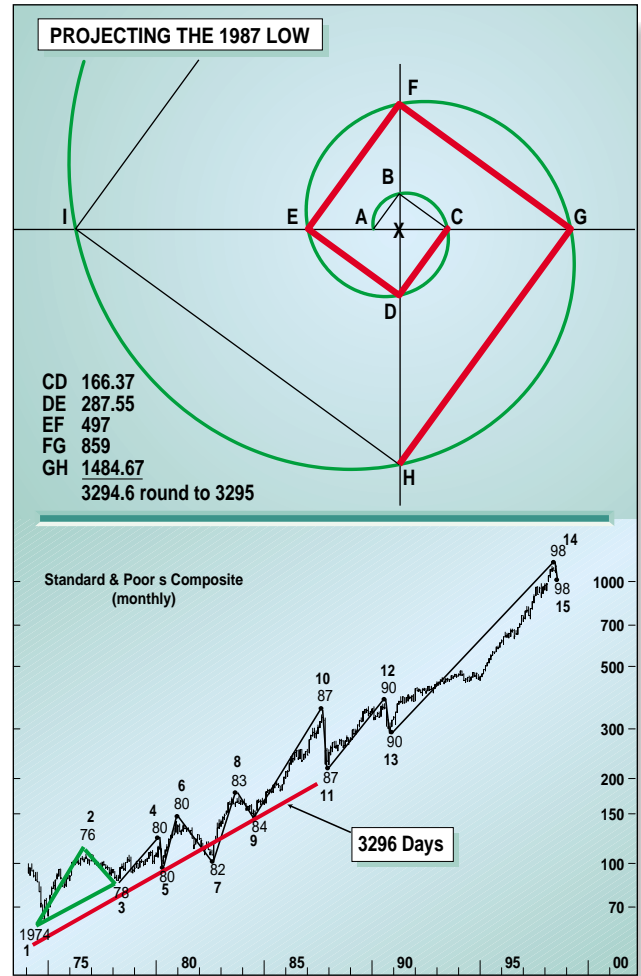
**FIGURE 15: 1982 LOW CONFIRMATION.** A simple three-term continuous proportion, A is to B as B is to C, using the constant ratio of growth and the two seed segments to confirm the 1982 low previously projected in Figure 6.

CD = 166.37  
DE = 287.55  
EF = 497 (seed segment)  
FG = 859 (seed segment)  
GH = 1.484.67  
HI = 2.566.35  
IJ = 4.435.6

The constant ratio of growth, 1.72837, is 26% larger than the 1.37293 for the spirals already analyzed. This rapid growth causes the spiral to expand and decrease so quickly that it cannot be drawn to scale without becoming distorted. The decreasing spiral becomes so small that it is unreadable. Therefore, the graphic portrayal of the 1.37293 growth ratio will also be used to illustrate this new set of spirals. Remember, while it is not to scale, the principles remain.

**EXAMPLES**

Now, let's look at examples using this new set of calculations. Figure 15 shows how a single spiral segment, generated immediately following the two seed segments, connects the



**FIGURE 16: RECONFIRMING THE 1987 CRASH LOW.** Figure 10 has already projected the October 20, 1987, low. The five spiral segments in Figure 15 repeat this projection with a total of 3,295 days. The actual number of days from the 1974 low to the 1987 low is 3,296 days.

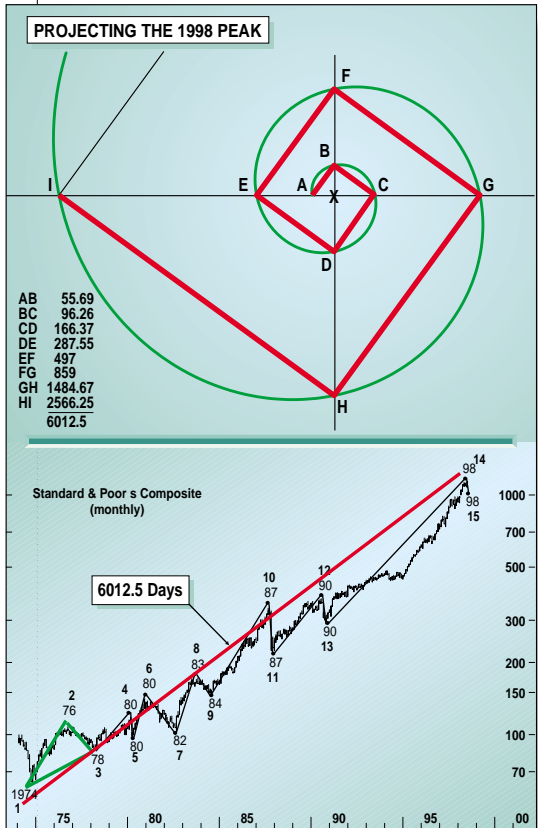
1976 peak to the 1982 low. This confirms the projection already made for the 1982 low by using three segments of the 497–362 spiral, illustrated in Figure 6. A simple three-term continuous proportion of A is to B as B is to C uses the constant ratio of growth and the two seed segments:

Segment	EF	FG	Segment	FG	GH
	497	859		1,484.67	

So 497 is to 859 as 859 is to 1,484.67; 1,487.67 (segment GH) is the time distance from point 2, the 1976 peak and terminus of seed segment 497, to point 7, the August 9, 1982, low.

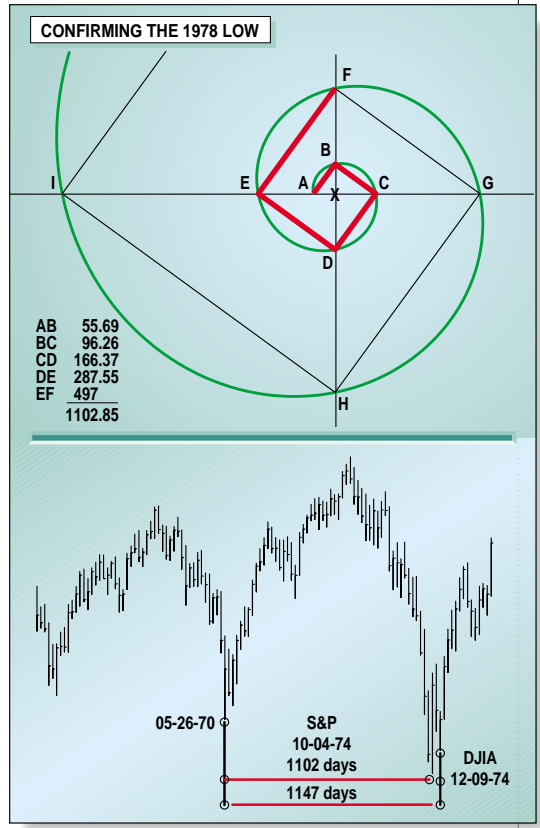
Another interesting example uses five spiral segments to confirm the 1987 crash low (Figure 16). Figure 11 has already projected the October 20, 1987, low. The five spiral segments in Figure 16 repeat this projection with a total 3,295 days. The actual number of days from the 1974 low to the 1987 low is 3,296 days.

And in more recent activity, Figure 17 shows that from the



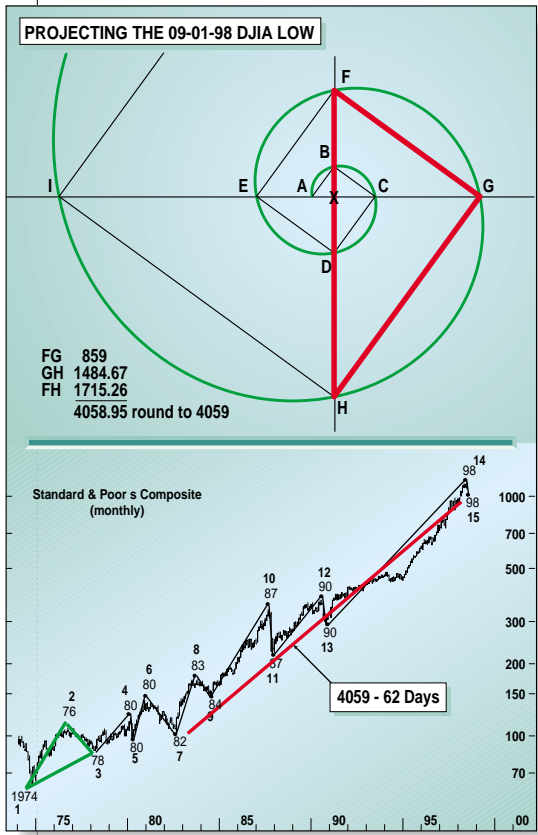
**FIGURE 17: RECONFIRMATION OF THE SUMMER 1998 PEAK.**

From the S&P 1974 low to July 20, 1998, is 6,012 days, the total of the eight spiral segments in Figure 17. This peak was also projected in Figure 12, illustrating the 4,028-day move from August 12, 1982.



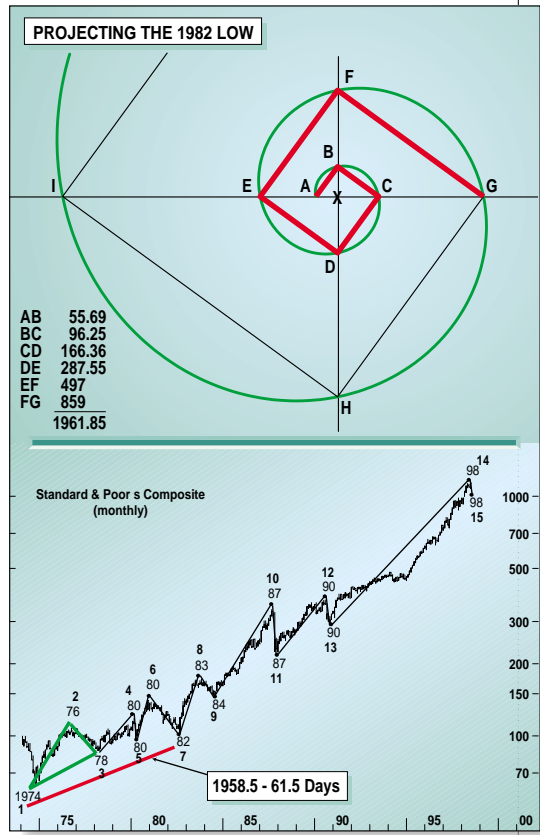
**FIGURE 18: CONFIRMATION TOOL.**

We showed in Figure 14 the 1,102-day time distance from the 1970 low to the S&P 1974. In this example, the 1,102 days appear as five contiguous spiral segments. The appearance of the 1970-74 1,102-day move in a spiral created by subsequent moves (1974-76-78) is a confirmation that the 1978-low day could be a very major pivot day.



**FIGURE 19: RIGHT TRIANGLES.**

Consider right triangle FGH; the legs are segments of the rectangular spiral, FG a seed segment, and GH the contiguous segment and also the market move from 1976 down to 1982. The hypotenuse is axis segment FH and its value is easily computed with the Pythagorean theorem. The perimeter of right triangle FGH is 4,059, the number of days from August 12, 1982, to September 1, 1998, the current DJIA low.



**FIGURE 20: BALANCE POINTS.**

A balance point is that day that lies exactly in the middle of two end pivots of a compound pivot. Since the compound pivot at the 1974 low was 45 days wide, the balance point would be 22.5 days after the S&P pivot, and 22.5 days before the DJIA pivot. The time distance from the balance point, at point 1, to the 1982 low, August 12, 1974, is 1,961.5 days.

S&P 1974 low to July 20, 1998, is 6,012 days, which is the total of the eight spiral segments in Figure 16. This peak was also projected in Figure 13, illustrating the 4,028-day move from August 12, 1982.

An additional example of using continuous spiral segments as a confirmation tool is Figure 18. Recall that in Figure 14, the 1,102-day time distance from the 1970 low to the S&P 1974 was considered the diameter of a circle, and reincarnated as the circumference of a circle on spiral segments. In this example, the 1,102 days appear as five contiguous spiral segments.

The appearance of the 1970-74 1,102-day move in a spiral created by subsequent moves (1974-76-78) is a confirmation that the 1978-low day could be a major pivot day. Figure 18 would be used in conjunction with the illustrated example in Figure 14 as additional confirmation.



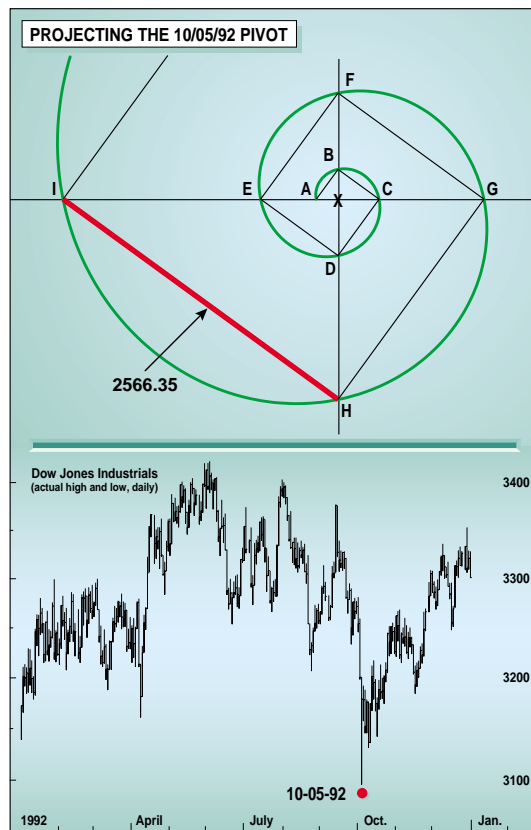
**OTHER TECHNIQUES**

Right triangles can also be used to identify important pivot points; Figure 19 illustrates this technique. Figure 8 introduced the use of axis segments, while Figure 14 introduced the concept of market moves appearing in different geometrical forms.

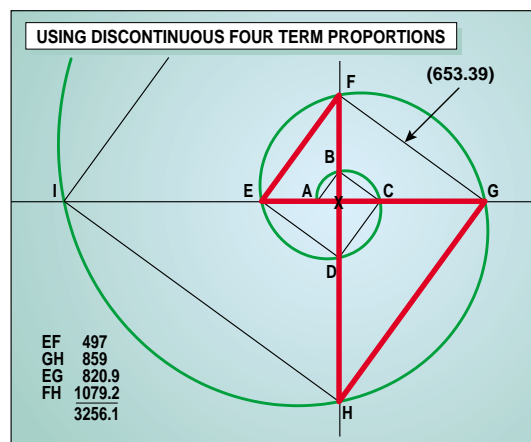
A very common form is the right triangle. Consider right triangle FGH, Figure 19. The legs are segments of the rectangular spiral, FG a seed segment, and GH the contiguous segment and also the market move from 1976 down to 1982. The hypotenuse is axis segment FH and its value is easily computed with the Pythagorean theorem. The perimeter of right triangle FGH is 4,059, the number of days from August 12, 1982, to September 1, 1998, the current DJIA low.

Another method deals with the issue of a compound pivot. As explained in the sidebar, a compound pivot occurs when the two indices record their extreme prices on different days. To deal with this, we use a balance point, which is that day exactly in the middle of two end pivots of a compound pivot. Since the compound pivot at the 1974 low was 45 days wide (Figures 2 and 20), the balance point would be 22.5 days after the S&P pivot and 22.5 days before the DJIA pivot. The time distance from the balance point at point 1 to the 1982 low, August 12, 1974, is 1,961.5 days. This confirms the projections in Figures 6 and 15. Balance points are used extensively in all of the Ermanometric algorithms.

Earlier, we stated that many major and minor market moves were influenced by the 1974-78 market moves. Figure 21, where a spiral segment, HI, added to the 1982 low, 6A, projects an important low in 1992, is the first example of a minor move, although it is minor only in relation to the other examples. A short-term trader would have considered the October 5, 1992, turn a major event. This pivot is 2,566 days from the August 12, 1982, low.



**FIGURE 21: 1992 LOW.** Spiral segments, HI, added to the 1982 low, 6A, projects an important low in 1992. This is the first example of a minor move, although it is minor only in relation to the other examples. A short-term trader would have considered the October 5, 1992, turn a major event. This pivot is 2,566 days from the August 12, 1982, low.



**FIGURE 22: TWO OPPOSING SIMILAR TRIANGLES.** Only the opposing triangles have been calculated, and the sum of their perimeters equals 3256. The number of days from the 1974 low to the 1987 peak is 3,257 days, as also projected in Figure 10.

## BEYOND THE BASICS

The 20 examples shown thus far are merely the tip of the iceberg of future turbulence created by the market action of 1974-78. There is a great deal more to this iceberg that will cause the Titanic market to continually change course at projected pivot days. Perhaps this is a poor analogy, since in this case the iceberg cannot sink the market! Additional exploration can be accomplished by calculating the square root of the growth ratio between 497 and 859. The growth ratio we have been using for these two seed segments is 1.72837, and the square root of the ratio is 1.31467, which we will now use as a growth ratio to get deeper inside the spiral.

$$(497)(1.31467) = 653.3934$$

$$(653.3934)(1.31467) = 859$$

Only the original seed segments are placed on the spiral. (The spiral diagram is not to scale.) The axes segments can be calculated, as explained previously.

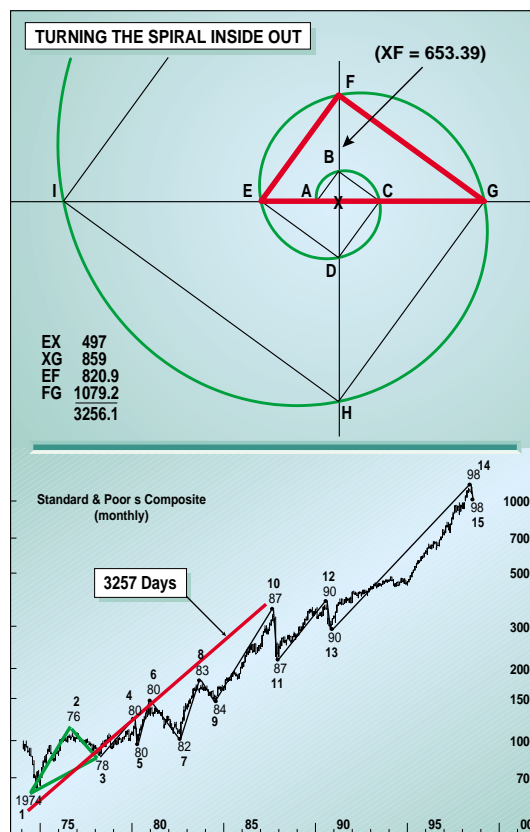
Now, in Figure 22, we are summing the perimeters of two opposing similar triangles. Only the opposing triangles have been calculated and the sum of their perimeters equals 3,256. The number of days from the 1974 low to the 1987 peak is 3,257 days, as also projected in Figure 10.

Moving to Figure 23, we see that if the value 820.9 (from Figure 22) is placed on segment EF, and segments FG, EX, and XG are calculated with the square root of the same constant growth ratio used throughout the 497–859 seed segment example, the result is a right triangle, EFG. The perimeter of this triangle equals the perimeters of the two opposing triangles in Figure 22. Earlier, I stated that the axes segments and spiral segments, by virtue of a common growth ratio, could be interchanged without changing the shape of the spiral. This principle is illustrated in Figure 23, where the axes segments EG and FH from Figure 22 are used as spiral segments and the spiral segments, EF and GH from Figure 22, become axes segments EX and XG. This type of exercise may be redundant, but I have presented it to illustrate different approaches to analyzing spiral segments.

## CONCLUDING COMMENTS

We may appreciate the markets for their harmonious and disciplined movements, and even as objects of beauty. However, that admiration can only bring esthetic rewards. A true belief in perfectly patterned markets should spur the reader to uncover more evidence of order and to profit from it. Ermanometry uses many other algorithms for pattern analysis, and not only do they have to confirm growth analysis projections, but spirals from different time frames must intersect at future pivot points to increase the potential of any specific date.

*William Erman, the founder of Ermanometry Research, wishes to express his appreciation to Sam Hale, CMT, chairman of the Body of Knowledge Committee, the Market Technicians Association, for his review and constructive commentary during the evolution of the bases of Ermanometry, and to*



**FIGURE 23: RECTANGULAR SEGMENTS AND AXES SEGMENTS CHANGE PLACES.** Since all segments of the diagram have the same growth ratio, the ratios can be interchanged without changing the shape of the spiral. Figure 23 is an example of switching the segments from Figure 22. Now the sum of the perimeter of triangle EFG equals 3,256.

*Robert Prechter, Jim Tillman, and Walter Bressert for pioneering work in making the investment community aware of the importance of timing analysis. This article is dedicated to Jeffrey Horowitz, the former director of The Foundation for the Study of Cycles, whose support has never wavered. Charts were supplied by Topline Investment Graphics.*

## RELATED READING

- Erman, William T. [1999]. *Ermanometry: The Perfectly Patterned Markets*, Ermanometry Research, Box 50785, Nashville, TN 37205.
- Dunham, William [1990]. *Journey Through Genius*, John Wiley & Sons.
- Gleick, James [1987]. *Chaos*, Viking Penguin, New York.
- Huntley, H.E. [1970]. *The Divine Proportion*, Dover Publications, New York.
- Reichenbach, Hans [1958]. *The Philosophy Of Space And Time*, Dover Publications, New York.
- Thompson, D'Arcy [1961]. *On Growth And Form*, Cambridge University Press.
- Topline Investment Graphics, PO Box 2340, Boulder, CO 80306-2340, 303 440-0157, www.topline-charts.com.

†See Traders' Glossary for definition

S&C